



ABO valve

GRIP THAT HOLDS

SERIES 900

// PN 6/10/16/Class 150

// DN 32 - 1600 (1" 1/4 - 64")

// Industrial applications

// Water, chemicals, gas

// Oil & gas, air



CE

DWG

Lloyd's Register



INTERFLANGES BUTTERFLY VALVES

WWW.ABOVALVE.COM

GENERAL INFORMATION

GENERAL CHARACTERISTICS

- Concentric design
- Shut-off and regulating device
- Split shaft
- Pivot fixed by pin (or screw - option) allows demounting (demountable version)
- Long neck of the body according to Heating Systems Regulation standards
- Orange epoxy painting RAL 2002 - 80 µm
- Vacuum max 0,2 bar absolute
- Movement of disc ensured by four-squared endstem
- Certificate ATEX (Group II, Category 1/2 GD TX)
- Approved for demanding GAS applications by certificate DVGW

APPLICATIONS

Butterfly valves series 900 are suited for many applications where tight shut-off is required, such as:

- Industrial Processing
- Water and Wastewater
- Dry Bulk Conveying
- Light Slurry Handling
- Paper Mills
- Food and Beverage
- HVAC (Heating, Ventilating & Air Conditioning)
- Non-mining environments and explosive atmosphere consisting of dust and gas (zones 0, 1, 20 and 21)

STANDARDS

LEAK TEST:

- EN 12266-1, Rate A
- ISO 5208, Rate A
- API 598, TAB. 5

FACE TO FACE ACC.:

- EN 558, SERIES 20
- ISO 5752, SERIES 20
- API 609, TAB. 2

TOP FLANGE:

- EN ISO 5211

CONNECTION

BETWEEN FLANGES:

- EN 1092-1
- DIN 2631
- ASME B16.5

WORKING STANDARD:

- EN 593 + A1

TYPE DESIGNATION

9 2 4 B

Version of body

- B = wafer
- T = lug
- F = double flange

Material of disc

- 0 - Brass 2.0402
- 1 - Aluminium bronze 2.0966
- 2 - Stainless steel 1.4308 (CF8)*
- 3 - Ductile iron 0.7040 (GGG40)*
- 4 - Stainless steel 1.4408 (CF8M)*
- 5 - HASTELLOY
- 6 - Stainless steel 1.4539 (Uranus B6)
- 7 - Titanium
- * Halar + Rilsan Coating optional

Material of seat

- 1 - NBR
- 2 - EPDM
- 3 - Carboxylic NBR
- 4 - VITON (FPM)
- 5 - Silicone Steam (MVQ)
- 6 - Silicone (VMQ)
- 7 - Epichlorohydrin
- 8 - HYPALON® (CSM)
- 9 - other variant

Series name

Series 900

Models

Wafer type B



Lug type T



Double flanged type F for DN 700 - DN 1600



PRODUCT QUALITY AND CONTROL

- ABO production facilities are certified in accordance to ISO 9001 quality system
- Test procedures are established according to: EN 12266-1, ISO 5208, API 598, ANSI/FCI 70-2
- Manufacture according to the requirements of the European Directive 97/23/CE - Equipment under pressure (Category III, modul B)
- All ABO valves pass pressure tests to 110% of rated pressure to ensure bubble tight shutoff
- All actuators are calibrated and cycle tested before shipment
- Material Traceability Rule - Certification is provided for all supplied valves as per customer's request
- Positive Material Identification - All materials are subjected to PMI testing in order to verify Material Traceability Certificate
- Certificates - Complete list of certificates can be found on www.abovalve.com



DESIGN BENEFITS

1) INTERNATIONAL STANDARD COMPATIBILITY

Top flange according to Standard ISO 5211 enables direct mounting of manual operators and power actuators. Longer necks of ABO butterfly valves result in insulation of ISO top flange (protection of mounted actuator) and meeting Heating Systems Regulation standards.

2) BLOW-OUT PROOF STEM SYSTEM

No up-movement of stem is ensured by securing pin in the body neck.

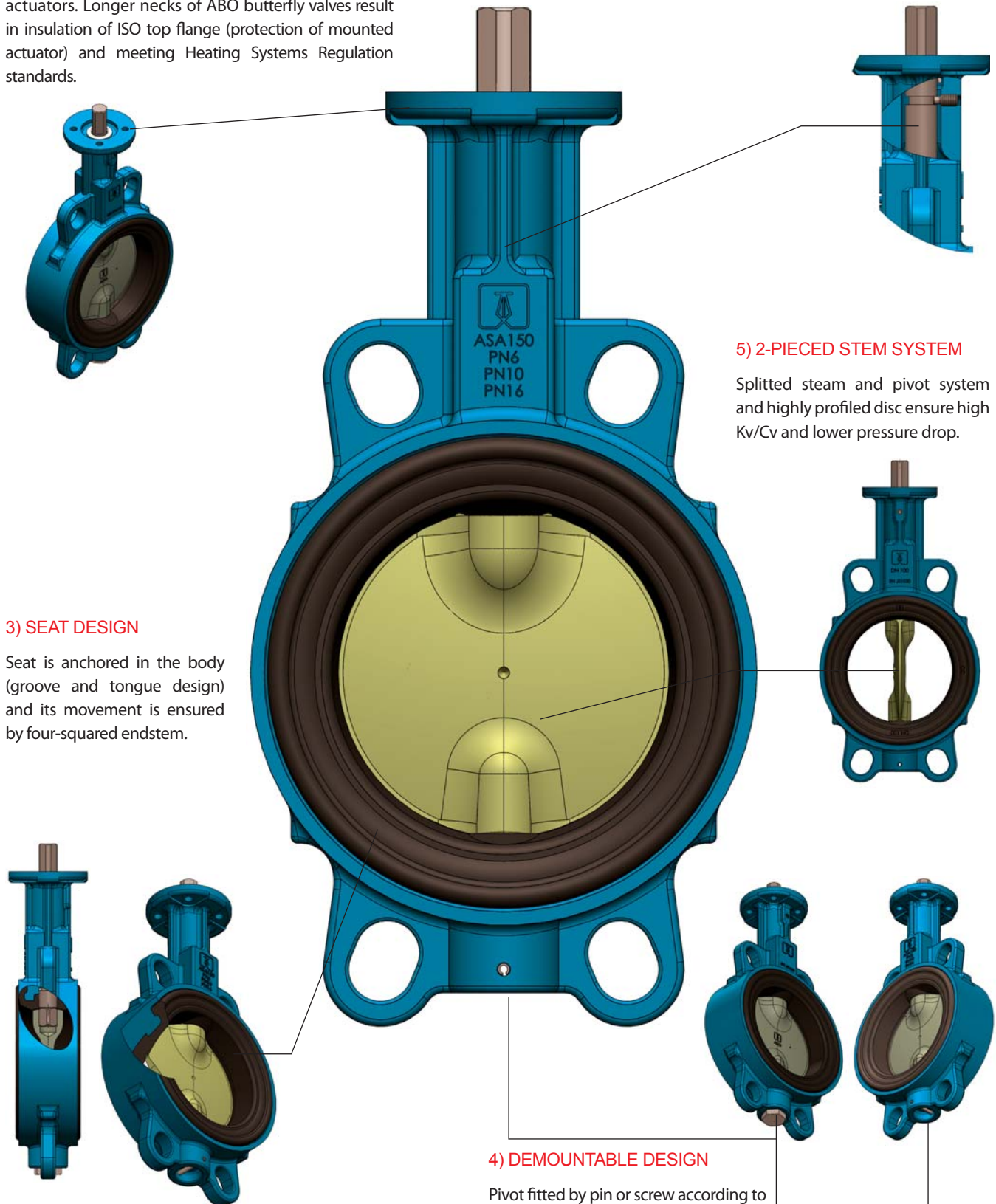

3) SEAT DESIGN

Seat is anchored in the body (groove and tongue design) and its movement is ensured by four-squared endstem.

5) 2-PIECED STEM SYSTEM

Splitting stem and pivot system and highly profiled disc ensure high Kv/Cv and lower pressure drop.

4) DEMOUNTABLE DESIGN

Pivot fitted by pin or screw according to customer's request allows demounting.

MATERIALS & TECHNICAL INFORMATION

DRAWING & MATERIALS

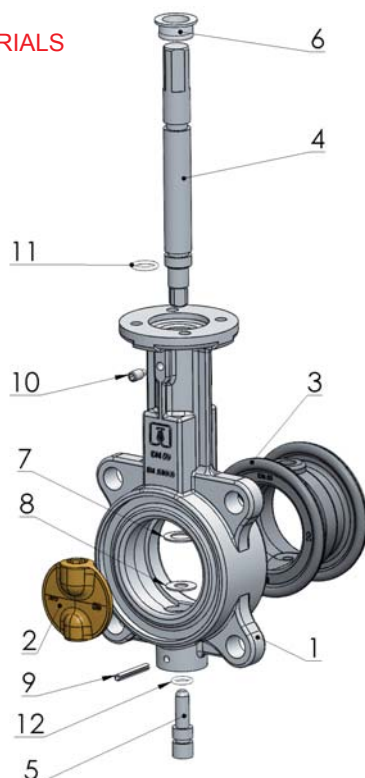

Item	Name	Material
1	Body	Ductile iron 0.7040 (GGG40) epoxy coated Carbon steel 1.0446 (A216 WCB) Low carbon content steel 1.1156 (A352 LCC) Stainless steel 1.4408 (CF8M)
2	Disc	0 – Brass 2.0402 1 – Aluminium bronze 2.0966 2 – Stainless steel 1.4308 (CF8) 3 – Ductile iron 0.7040 (GGG40) 4 – Stainless steel 1.4408 (CF8M) 5 – HASTELLOY 6 – Stainless steel 1.4539 (Uranus B6) 7 – Titanium
3	Seat	1 - NBR - 10°C + 100°C 2 - EPDM - 25°C + 125°C 3 - Carboxylic NBR - 10°C + 100°C 4 - VITON (FPM) - 15°C + 150°C* 5 - Silicone Steam (VMQ) - 30°C + 140°C 6 - Silicone (VMQ) - 30°C + 150°C 7 - Epichlorohydrin - 30°C + 70°C 8 - HYPALON® (CSM) - 25°C + 120°C 9 - NBR 70-AG - 10°C + 60°C - NBR conduct - 10°C + 80°C
4	Shaft	Stainless steel 1.4021 (AISI 420)
5	Pivot	Stainless steel 1.4021 (AISI 420)
6	Bushing	Delrin (up to DN 300) Brass (from DN 350)
7	Distance ring	Stainless steel
8	Distance ring	Stainless steel
9	Pin	Stainless steel 1.4401 (AISI 316)
10	Retaining screw	Stainless steel
11	Shaft O-ring	NBR, EPDM, VITON is an option
12	Pivot O-ring	NBR, EPDM, VITON is an option

Execution in other material types can be provided upon request. Choice of the seat and disc materials for various media will be recommended upon specific enquiry. Max. temperatures for each material of seat are accepted only for a specific medium and short time exposure.

* Max. temperature for water services only up to 80 °C.

INSTALLATION BETWEEN FLANGES (DN 32-600)

Vers.	PN / DN	32/40	50	65	80	100	125	150	200	250	300	350	400	450	500	600
B	PN 6											•	•	•	•	•
	PN10															
	PN16														•	
	Class 150											XX	XX	•	•	•
T	PN 6	•	•	•	•	•	•	•	•	•	•	•	•	X	X	X
	PN10													•	•	•
	PN16								•	•	•	•	•	•	•	•
	Class 150	•	•	•	•	•	•	•	•	•	•	•	•	•	•	•

INSTALLATION BETWEEN FLANGES (DN 700 – 1600)

Vers.	PN / DN	700	800	900	1000	1100	1200	1300	1400	1500	1600
F	PN 6	•	•	•	•	•	•	•	•	•	•
	PN 10										
	PN 16	•	•	•	•	•	•	•	•	•	•
	Class 150	•	•	•	•	•	•	•	•	•	•

<input type="checkbox"/>	standard
<input checked="" type="checkbox"/>	upon request
<input type="checkbox"/>	not suitable
<input checked="" type="checkbox"/>	standard for GGG40

* For JIS 5K/10K, please consult with ABO.

WORKING CONDITIONS

- **Max working pressure**
 - o DN 32 - 600: 16 bar
 - o DN 700 - 1600: 10 bar (16 bar upon request)
- **Temperature range - max:** - 30°C + 150°C (- 22°F + 302°F), depends on material selection

When temperature of medium increases over + 120 °C, the max allowed pressure falls from 16 bar to 14,4 bar and from 10 bar to 9 bar

COATING

- Standard coating is orange epoxy painting RAL 2002 - 80 µm
- Based on customer's request, it is possible to modify the colour or provide higher degree of coating

ACTUATION & TORQUES

ACTUATION POSSIBILITIES

All ABO handles, manual gear operators, pneumatic and electric actuators can be mounted directly to ABO butterfly valves, thus eliminating brackets or couplings. This allows for simple installation in the field, minimizes possible misalignment and decreases overall height.

MANUAL ACTUATION: HANDLEVER

Handlever can be supplemented with contacts for signalisation of endpositions.

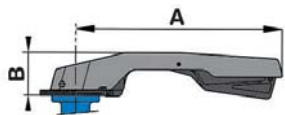

DN	32 - 80	100 - 150	200*
A	200	273	362
B	76	78	73
Weight	0,35	0,4	1,45

*DN 200

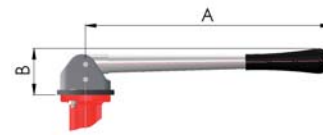

MANUAL GEARBOX WITH HANDWHEEL

ABO gearbox series of manual actuators combines state of art production technology, with cast iron and pressed steel construction, to provide a smooth and trouble-free operation for heavy duty on-off and throttling service of ABO valves. The rugged, cast iron body seals is weatherproof to IP65. A self-locking gearing holds the valve in the desired position. Further features include a readily accessible handwheel, adjustable stopcrew for closed position, removable splined drive bush with indexing facility and a facility to lock handwheel with padlock and chain. Gearboxes, as well as handlevers, can be supplemented with contacts for signalization of endpoints. Aluminium gearbox for lightweight operation also available.

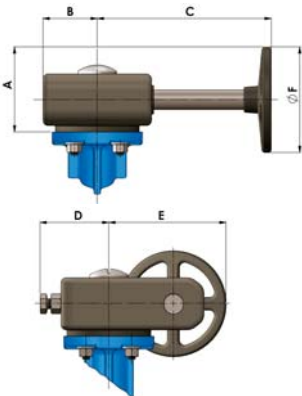

DN	32 - 150	200	250-300	350	400	450	500	600
A	89	89/127**	155	213	263	275	275	350
B	51	51	66	83	83	99	99	126
C	152	152/185**	272	302	334	279	279	360
D	44	44	59	70	70	96	96	118
E	101	101/138,5**	177	242	292	314	314	423
F	125	125/200*	250	350	450	450	450	600
Weight	1,6	1,6	3,7	6,6	6,6	14,5	14,5	27,2
Wheel	SR5	SR5/SR8*	SR10	R14	R18	R18	R18	R24

Dimensions mentioned in mm, weight in kg. Valid for SE Series (DN 32 - 400), M Series (DN 450 - 600).

*Optional

**Acc. to handwheel choice

ACTUATORS

- PNEUMATIC ACTUATORS - ABO pneumatic actuators Series 95 are rack and pinion, opposed-piston actuators available in two versions: single acting & double acting
- ELECTRIC ACTUATORS - ABO series 97 electric actuators are designated for quarter turn operating application. Electric actuators of 24V, 230V and 400V can be installed on ABO butterfly valves.

OPERATING TORQUES UPON WORKING PRESSURE (NM)*

DN	32/40	50	65	80	100	125	150	200	250	300	350	400	450	500	600
PMA 6 bar	6	8	15	20	38	55	70	100	150	235	480	750	1180	1380	2050
PMA 10 bar	8	10	17	25	46	70	80	125	220	290	530	1200	1550	2050	2700
PMA 16 bar	10	12	20	30	55	85	100	150	290	380	580	1650	2100	2700	3750

DN	700	800	900	1000	1200	1400	1600
PMA 10 bar	3500	4500	6000	8950	12600	18500	24400

The above mentioned torques are valid for valves with EPDM seat only, and under the condition that the working medium is liquid. While actuating the valve, the above mentioned figures should be multiplied by a coefficient of 1,2. Using a NBR seat, it is necessary to apply a coefficient of 1,8 for dimensions up to DN 300 and a coefficient of 1,32 for dimensions DN 350 and above. In case the medium is gaseous, or if it contains abrasive particles, it is necessary to apply a secondary coefficient of 1,35. If the working conditions are specific, it is recommended to discuss the selection of the actuator with the manufacturer.

DIMENSIONS DN 32 - 1600 (1¹/₄ - 64^{''})

DN 32 - 600 (1¹/₄ - 24^{''}) PN 6/10/16/Class 150

Lug type T

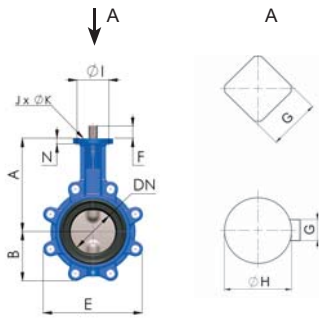

Wafer type B

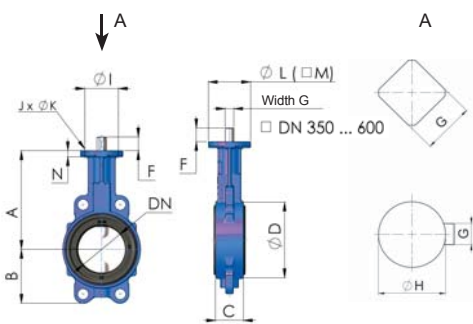

DN	mm	32	40	50	65	80	100	125	150	200	250	300	350	400	450	500	600		
		inch	1 ¹ / ₄	1 ¹ / ₂	2 ^{''}	2 ¹ / ₂	3 ^{''}	4 ^{''}	5 ^{''}	6 ^{''}	8 ^{''}	10 ^{''}	12 ^{''}	14 ^{''}	16 ^{''}	18 ^{''}	20 ^{''}	24 ^{''}	
Version	B	136	136	146	153,5	163	172,5	192,5	205	234	270	310	325	365	375	482	562		
	T															485	565		
Valve dimensions	B	54	54	64	72	89	105	118	128	166	202	237	271	314	330	363	464		
	C	33	33	43	46	46	52	56	56	60	68	78	78	102	114	127	154		
	D	78	78	96	113	128	150	184	212	268	320	378	435	488	544	590	695		
	E	110	110	115	129	174	204	234	255	319	396	465	509	590	610	682	810		
	F	25	25	25	25	25	25	25	25	25	30	30	36	36	80	80	80		
Endshaft dimensions	G	14										17	22	22	27	27	10	12	14
	H	-	-	-	-	-	-	-	-	-	-	-	-	-	-	Ø38	Ø42	Ø50	
	I	50/70		50			70			102		102	125	140	140	140	165		
ISO TOP Flange	J	4																	
	K	7							9		10,5	10,5	14	18	18	18	23		
	L	-	-	70			-	-	-	-	-	-	-	-	175	175	210		
Flange dimensions	M	70	70	-	-	-	-	75	75	75	105	105	130	140	-	-	-		
	N	8	8	8	8	8	8	9,5	9,5	14	17	17	17	21	22	25	25		
	Weight (kg)	Type B		1,9	1,9	2,7	3,2	3,7	4,7	6,7	8,4	13,3	22,0	29,3	46,4	69,8	83,0	112	216
	Type T		2,3	2,3	3,0	3,7	4,8	6,1	9,2	10,2	15,3	28,4	41,2	62	96,3	130	149	288	
ISO Flange	F05/F07							F07		F10		F12		F14		F16			

DN 50 - 150 (2^{''} - 6^{''}) PN6 / PN10 / PN16 / ANSI 150#

DN	mm	50	65	80	100	125	150
		inch	2 ^{''}	2 ¹ / ₂	3 ^{''}	4 ^{''}	5 ^{''}
Version - F	A	150	175	188	200	213	226
Valve dimensions	B	82	90	95	114	127	143
	C	43	46	46	52	56	56
Endshaft dimensions	F	30	30	30	30	35	35
	H	11	11	11	14	14	14
ISO TOP Flange	I	50	50	50	70	70	70
	J	4	4	4	4	4	4
	K	8	8	8	10	10	10
	L	65	65	65	90	90	90
ISO Flange		F05	F05	F05	F07	F07	F07

For version PN 16 / Class 150 upon request.

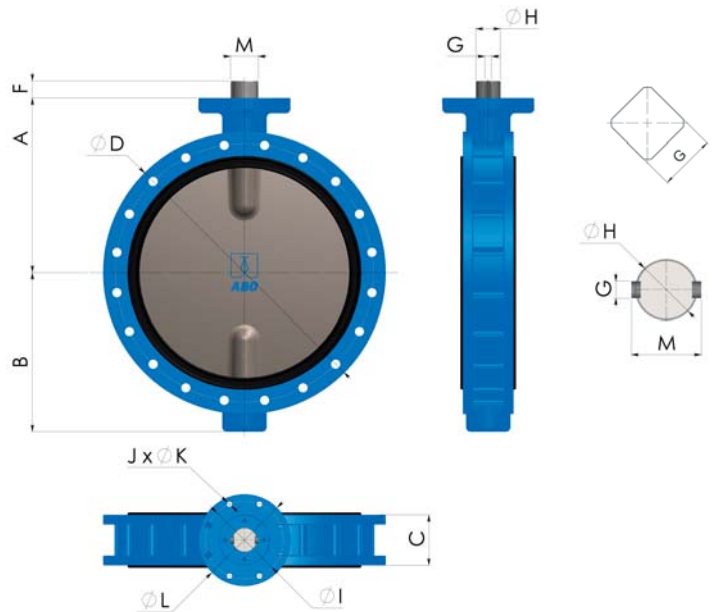

EUROPEAN UNION
EUROPEAN REGIONAL DEVELOPMENT FUND
INVESTMENT IN YOUR FUTURE

All statements, technical information in this brochure are tentative and for general use only and do not constitute a recommendation or guarantee for any specific service or application requirement. Consult ABO representative or factory for specific requirements and material selection for your intended application. The right to change or modify product design or product without prior notice is reserved. Binding specification will be provided in each offer. ABO valve accepts no liability for damages caused by bad interpretation or use of the information included in this brochure.

30. 9. 2014

Data subject to change.

Company HQ – Czech Republic:
ABO valve, s.r.o.
Dalimilova 285/54, 783 35 Olomouc
Tel: +420 585 202 226, +420 585 224 087
Email: export@abovalve.com
www.abovalve.com

Slovakia:
ABO Slovakia, s.r.o.
Banská Bystrica
Tel: +421 484 145 633
Email: aboslovakia@aboslovakia.sk
www.aboslovakia.sk

Russia:
ABO ARMATURA Ltd.
Smolensk
Tel: +7 4812 31 28 27
Email: aboarmatura@yandex.ru
www.aboarmatura.ru

Singapore:
ABO Valve Pte. Ltd.
Singapore
Tel: +65 96194562
Email: lsw@abovalve.com
www.abovalve.com

China:
ABO Flow Control
Beijing
Tel: +86 13601522831
Email: wen@abovalve.com
www.abovalve.com

Bahrain:
ABO Middle East
Kingdom of Bahrain
Tel: +973 - 3444 9065
Email: jimichen@abovalve.com
www.abovalve.com